

Automatic Float Drain

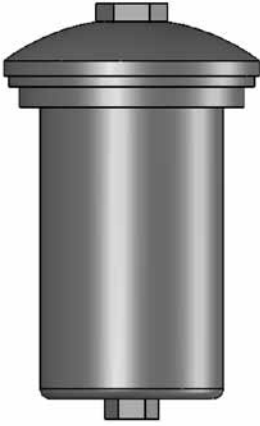

FD-25 and FD-50 Models

Two Models to fit most applications. Rugged zinc cast housing. Equipped with quick disconnect bowls for easy servicing. Economical cost.

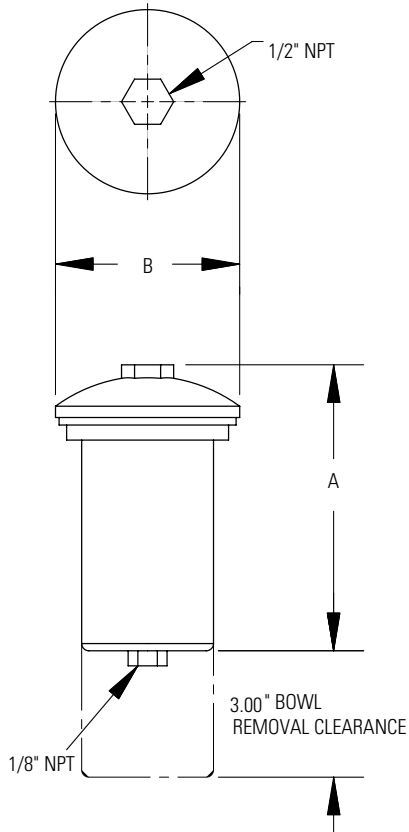

Dimensions

MODEL NUMBER	A	B
FD-25	4.75	3.06
FD-50	8.50	4.75

Specifications

MODEL NUMBER	PART NUMBER	PSI MAX	TEMP °F MAX	WEIGHT LBS (APPROX)
FD-25	66278	200	175	2.0
FD-50	66279			5.0